



KV-7

BUTTERFLY VALVE/WAFER TYPE

GENERAL FEATURES

The closing element in the butterfly valves is a rotating shaft that is placed on a vertical axis. The sealing is provided between the metal flap and the elastic or plastic sealing elements covering the inside of the body. The sealing element also serves as a flange seal between the valve and the pipe.

Advantages of such valves are; low pressure loss, easy opening and closing, good sealing, light weight and small footprint.

The Cona KV-7 Wafer Type Butterfly Valves should be checked to see if they are moving freely during the installation. The valve stem may be horizontal or vertical. However, horizontal installation on DN300 should be preferred.

Product Features:

Body: GG25 Cast iron

Disc: GGG 40.3 Ni Plated Cast Iron

Stem: DN25-DN300=SS420

DN350-DN600=SS431

Connection: Wafer Type

Max. Working Temperature: 130 °C

Application Areas:

- Heating, ventilating and air conditioning systems
- Water treatment and distributing systems
- Mining industry
- Shipbuilding and drilling plant
- Food and chemistry industries
- Fire extinguisher systems
- Water, sea water, dust, gas, wastewater and air

Notes:

It is recommended to use reducer type for all diameters in butterfly valves. There are only reducer type production on DN350 and above Butterfly valves.

Actuator Types

- Hand operated
- Reducer
- Single Action Pneumatic Actuator
- Double Action Pneumatic Actuator
- With Electric Actuator / On-Off (Manual Arm)

Pressure Class	Diameter (mm)
PN16	DN (25-300)
PN10	DN (350-600)

Gasket Material	Min. Temp. (°C)	Max. Temp. (°C)
H-EPDM	-10	130

KV-7 BUTTERFLY VALVE/WAFER TYPE

DN25-DN150

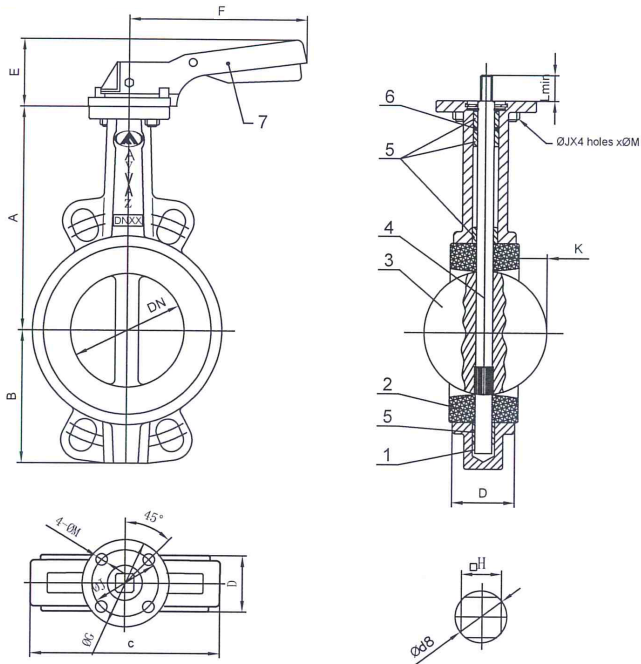

DN200-DN300

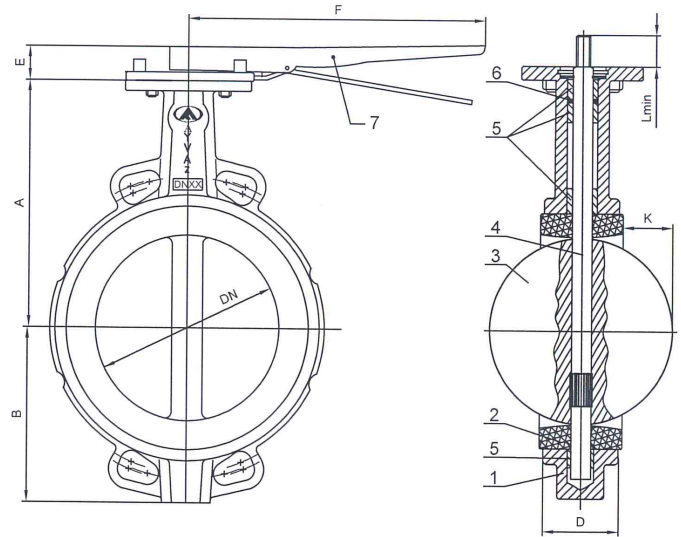

PRODUCT MATERIAL

Part No.	Component	Material
1	Body	GG25 Cast iron
2	Gasket	EPDM
3	Disc	GGG 40.3 Ni Plated Cast Iron
4	Shaft	SS420
5	Ring	Teflon
6	O-Ring	EPDM
7	Lever	Aluminum / Forged Iron

DN	A	B	K	D	E	F	ØG	H	ØJ	Lmin	ØM	Ød8	kg
	±2	±2	±2	±1	±1	±1	±1	±0.5	±1	±1	±1	±0.5	
25	121	53	—	33	70	195	65	7x7	50	32	7	9	1.8
32	121	57	—	33	70	195	65	7x7	50	32	7	9	1.85
40	130	61	2.65	33	70	195	65	9x9	50	32	7	11.8	2
50	136,5	77	2.9	43	70	195	65	9x9	50	32	7	11.8	2.5
65	142	87,5	6.9	46	70	195	65	9x9	50	32	7	11.8	2.9
80	158	95	14.5	46	70	195	65	9x9	50	32	7	11.8	3.4
100	180	107	23.7	52	70	195	65	11x11	50	32	7	14.5	4.3
125	192	121,5	32.3	56	71	278	90	14x14	70	42	9	18.9	6.6
150	215	144	48	56	71	278	90	14x14	70	42	9	18.9	7.8
200	241,5	171	68.7	60	40	355	125	17x17	102	36	11	22.5	14.5
250	280	205	88.8	68	44	507	150	22x22	125	38	13	29.8	25
300	310	235	109.8	78	44	507	150	27x27	125	38	13	31.6	34

KV-7 BUTTERFLY VALVE/WAFER TYPE

DN350-DN600

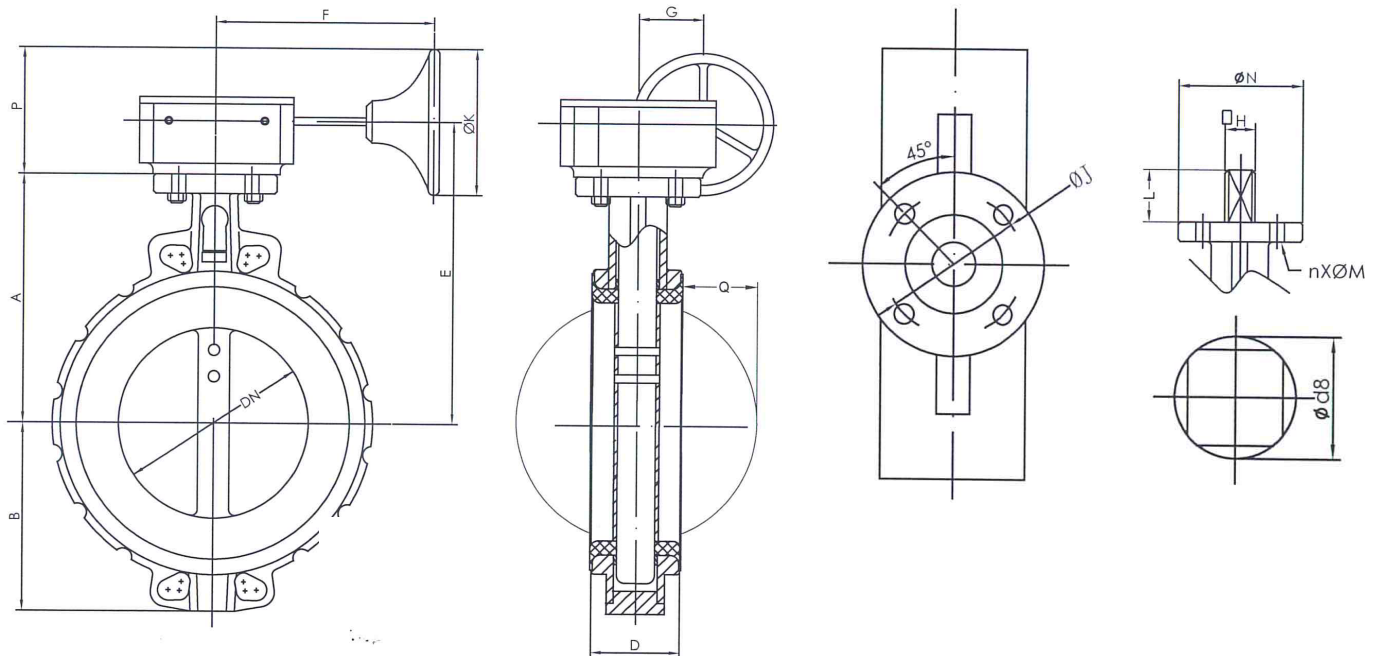

DN	A	B	D	E	F	G	P	ØK	ØJ	H	ØN	Ød8	Q	L	nxØM	kg
350	334	260	78	379	223	78	190	300	125	27x27	150	31.6	127.8	45	4xØ14	54.5
400	361	307	88	423	270	120	208	400	125	27x27	150	33.2	143.8	50	4xØ14	89.85
450	401	339	114	463	270	120	258	400	165	30x30	210	37.94	163.3	50	4xØ22	107.4
500	480	368	127	545	339	120	222	300	165	36x36	210	41.12	182.4	65	4xØ22	155.75
600	656	459	154	630	339	120	222	300	165	46x46	300	50.62	219.3	70	4xØ22	231.1

KV-7 BUTTERFLY VALVE/WAFER TYPE

Screw Connection Dimensions

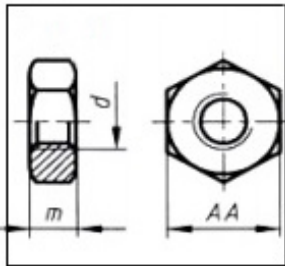

d (mm)	M10	M12	M16	M20	M24
AA	17	19	24	30	36
m	8	10	13	16	19

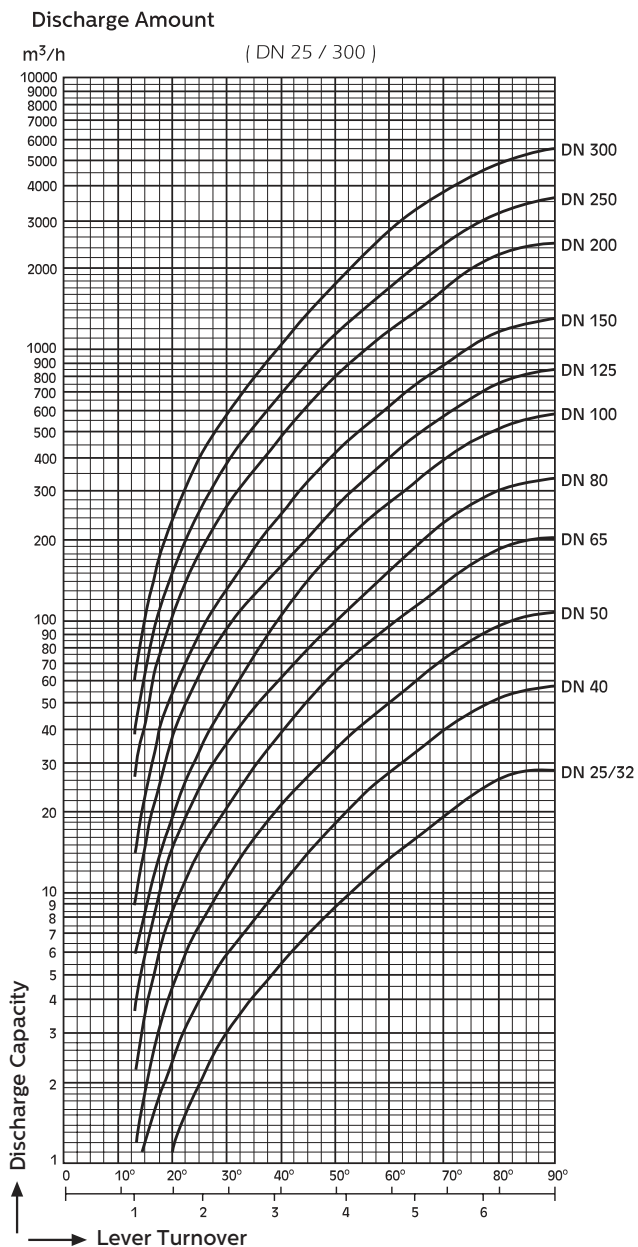

Dia. mm	Torque (Nm)	
	10 Bar	16 Bar
25	9	10
32	9	10
40	11	12
50	15	16
65	24	26
80	31	33
100	48	53
125	73	81
150	106	119
200	177	194
250	281	308
300	410	595
350	475	969
400	746	1307
450	1112	1787
500	1356	2288
600	2468	3711

Pipe Diameter		DISC OPENING ANGLE (DEGREE)								
MM	INC	10	20	30	40	50	60	70	80	90
40	1½	0,048	2,4	5,6	12	21,6	35,2	56	84	92
50	2	0,06	3	7	15	27	44	70	105	115
65	2½	0,10	6	12	25	45	75	119	178	196
80	3	0,20	9	18	39	70	116	183	275	302
100	4	0,30	17	36	78	139	230	364	546	600
125	5	0,50	29	61	133	237	392	620	930	1022
150	6	0,80	45	95	205	366	605	958	1437	1579
200	8	2	89	188	408	727	1202	1903	2854	3136
250	10	3	151	320	694	1237	2047	3240	4859	5340
300	12	4	234	495	1072	1911	3162	5005	7507	8250

KV-7 BUTTERFLY VALVE/WAFER TYPE

3D APPLICATION SAMPLE - 1

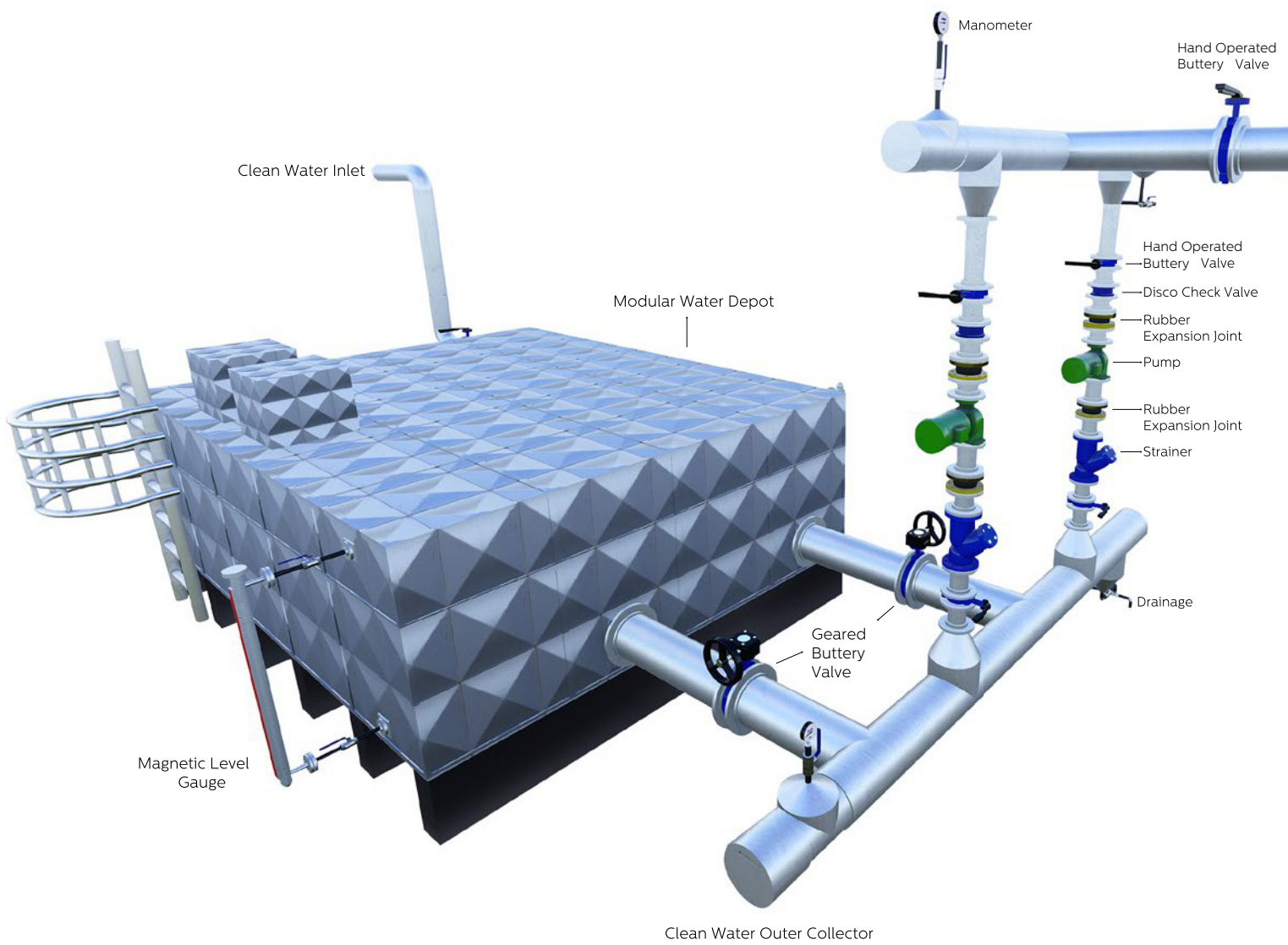

KV-7 BUTTERFLY VALVE/WAFER TYPE

3D APPLICATION SAMPLE - 2

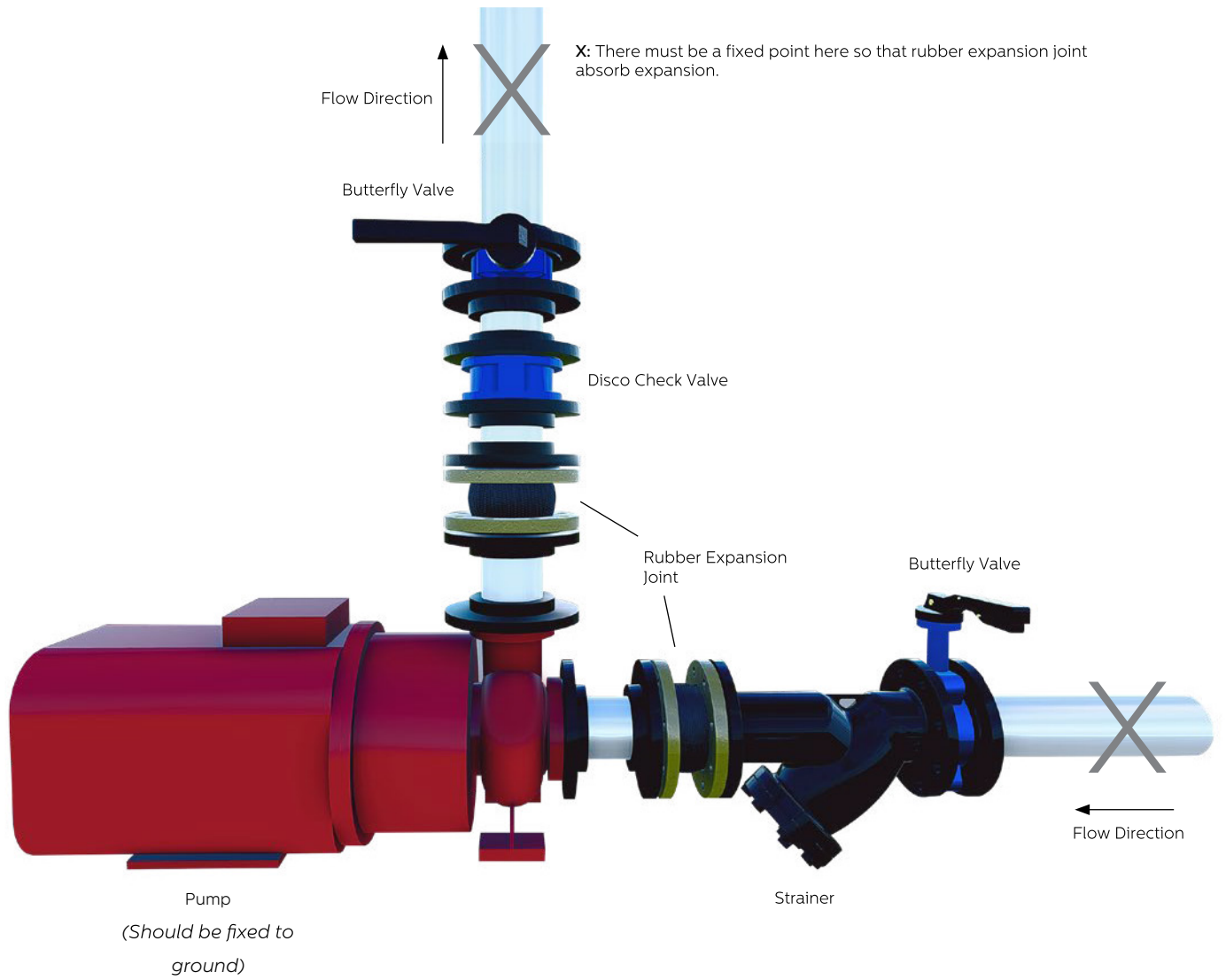

KV-7 BUTTERFLY VALVE/WAFER TYPE

INSTALLATION 1

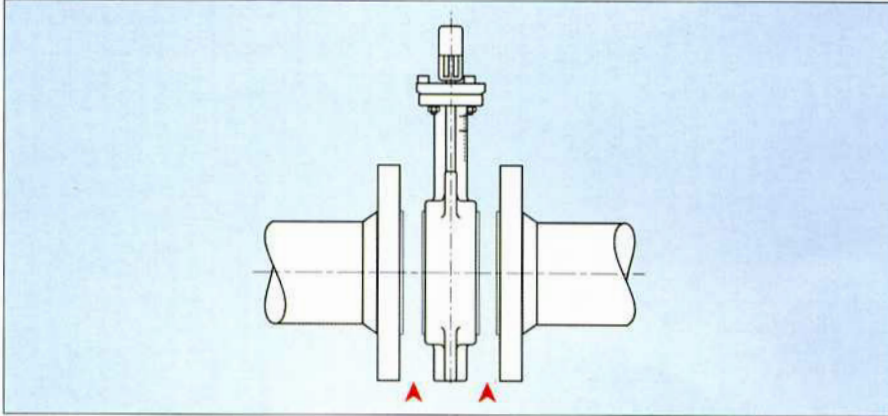

When mounting the valve on the mounting surface, make sure that there is sufficient clearance between the flanges. Valve surfaces that are attempted to be installed without sufficient distance may be damaged.

INSTALLATION 2

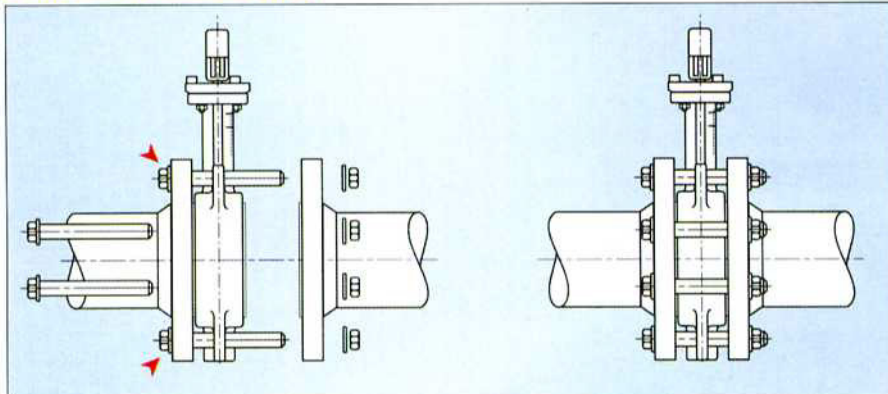

During assembly, first assemble the valve with a flange bolt, but do not tighten the bolts, as a second warning, set the body to center the pipe. Then tighten the nuts in the opposite direction, crosswise, until the valve body and pipe flange surfaces touch each other.

INSTALLATION 3

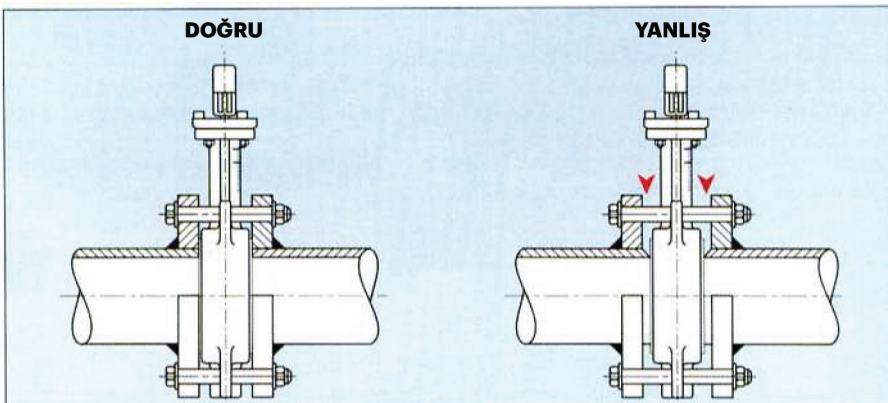

On the pipe surfaces where the butterfly valve is to be mounted, it is absolutely necessary to avoid the sharp points of the pipe ends and the diameters of the pipe. Pointed spikes and burrs on the pipe mounting surface can cause the rubber surfaces of the butterfly valve to be destroyed.

KV-7 BUTTERFLY VALVE/WAFER TYPE

INSTALLATION 4

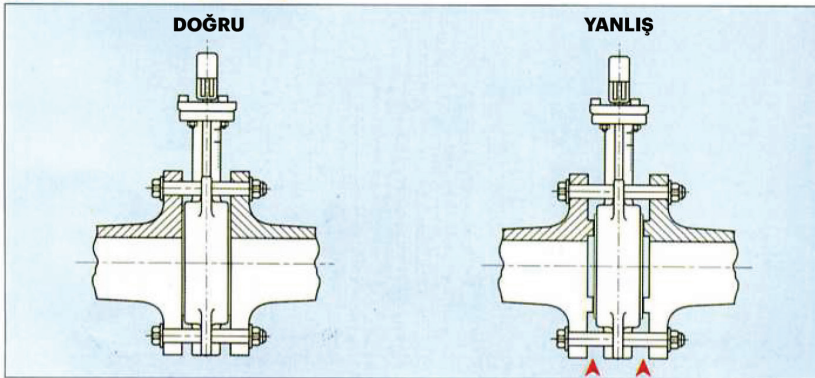

Installation the butterfly valve, it is important to use the correct connecting flange while the valve. The connection flange to be used must cover the maximum surface area of the butterfly valve.

INSTALLATION 5

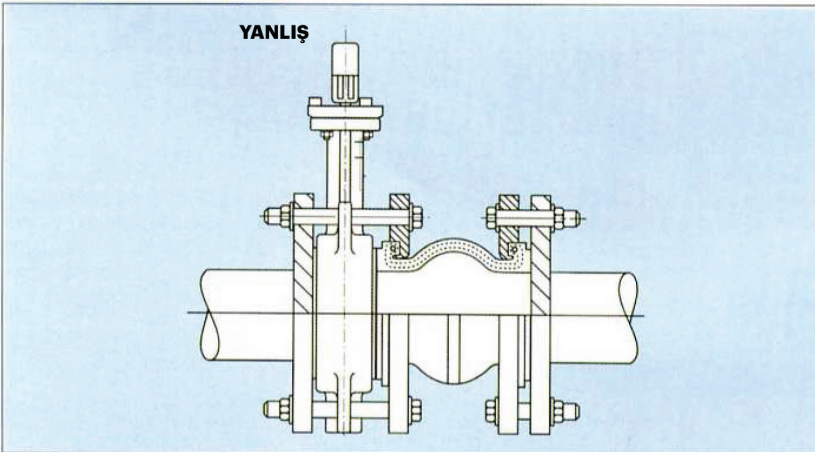

While installing the butterfly valve, it is important that rubber surfaces do not touch each other. Best installation of butterfly valve is the rubber surface of the valve and the metal surface of the pipe flanges to touching each other. The valve may come in contact with the sealing surface of the rubber compensator and may not close.