

X-PRESSED AXIAL EXPANSION JOINTS



Externally pressurised expansion joints are designed as the most appropriate solutions when the expansion joints must absorb very large axial movements under high pressure. Compensating larger amount of thermal expansions by axial expansion joints are only possible by increasing the number of corrugations of the bellow, but this increases the possibility of squirm risk. Cona's Externally pressurized expansion joints provide the most suitable solution for high axial movement needs. There are no limits to the size of axial movement that can be absorbed by this type of expansion joint.

Advantages of Ex-pressed Expansion Joints

- Bellows design according to EJMA coding system.
- Construction according to EN14917 standard.
- Smooth flow over the expansion joint helps to minimize pressure loss
- Bellows protection against outer affects.
- Bellows corrugations are safe from residues of aggressive liquids or steam
- Preventing axial inaccuracies increases the system safety
- Internal guide rings provide highly stable structure for connections

Application Areas

- Steam processing pipelines.
- HVAC piping lines.
- Industrial process & applications.
- Power generation & Energy plants.

DESIGN (EN 14917&EJMA)

Bellow Material	Stainless Steel AISI 321 (Opt.304,316L,316Ti,309)
Connection Types	Fixed and Floating Flanged, Welded Ended & Grooved
Flange Material	PN 16, St.37.2 as standard, the material can be customised on request
Inner Sleeve	Available in stainless steel AISI 321 (Opt. 304,316L,316Ti,309) on request
Accessories	Inner sleeve, cover, counter flange, gaskets, insulation etc. are available on request.
Certificates	Material certificate 3.1 according to EN 10204 and /or ASME PED 2014/68/EU Cat.III Mod.H

Operation Conditions

Operating Temperature	-10°C/+550°C
Operating Pressure	Standard pressure rating is PN16 Can be produced with different pressure rates PN 2,5-63 PN corresponds to the allowable operating pressure at room temperature

Important

Standard models are produced as un-restrained, fixed points should be created as to withstand springing force as well as pressure thrust caused by the system pressure. For detailed information, get in contact with Ayvaz's expert sales team. We strongly advise against the use of expansion joints and bellows for misalignment. Torsion on bellow parts are not desirable and should be eliminated.

X-PRESSED AXIAL EXPANSION JOINTS

X-Pressed Expansion Joints (One end with Fixed, other end with Floating Flange)

With fixed flange			
Type	Expansion Amount	Available Sizes (DN)	Pressure Class (PN)
DBKF-30	30 mm (-20/+10)	25-5000	16

With floating flanges			
Type	Expansion Amount	Available Sizes (DN)	Pressure Class (PN)
DBKF-60	60 mm (-40/+20)	25-5000	16

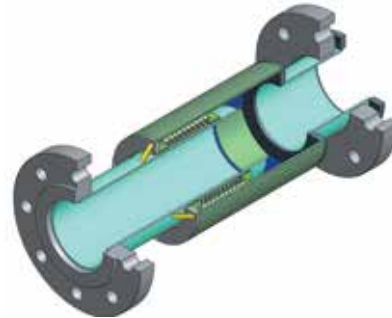
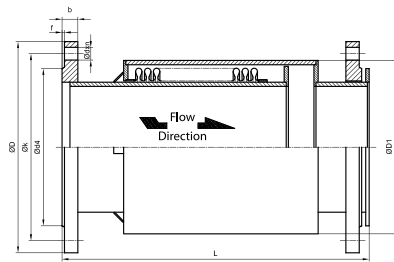

Bellows Information				DBKF-30			DBKF-60		
DN	Ødi	Ødo	Effective Bellow Area cm ²	L	Axial Spring Rate N/mm	Code	L	Axial Spring Rate N/mm	Code
DN25	38	48,2	14,58	360	82,1	702.060.201.002	490	41,1	702.060.202.002
DN32	42,4	55	18,62	360	49,7	702.060.201.004	490	24,8	702.060.202.004
DN40	48,3	61	23,44	380	60,8	702.060.201.006	500	30,4	702.060.202.006
DN50	60,3	76	36,46	370	104,5	702.060.201.008	480	55,7	702.060.202.008
DN65	76,1	95	57,45	370	87,8	702.060.201.010	470	43,9	702.060.202.010
DN80	88,9	111	78,42	370	178,9	702.060.201.012	470	89,4	702.060.202.012
DN100	114,3	140	137,09	380	252,2	702.060.201.014	480	126,1	702.060.202.014
DN125	139,7	164	181,01	380	320,0	702.060.201.016	490	160,0	702.060.202.016
DN150	168,3	200	266,20	400	196,4	702.060.201.018	510	98,2	702.060.202.018
DN200	219,1	250	431,86	420	694,2	702.060.201.020	530	347,1	702.060.202.020
DN250	273	323	697,11	440	590,0	702.060.201.022	540	295,0	702.060.202.022
DN300	323,9	380	972,37	460	496,8	702.060.201.024	570	248,4	702.060.202.024

Flange (DIN EN 1092/1) PN 16							
DN	ØD	Øk	Ød4	f	b	Ødxn	
DN25	115	85	68	2	16	Ø 14x4	
DN32	140	100	78	2	18	Ø 18x4	
DN40	150	110	88	3	18	Ø 18x4	
DN50	165	125	102	3	20	Ø 18x4	
DN65	185	145	122	3	20	Ø 18x4	
DN80	200	160	138	3	20	Ø 18x8	
DN100	220	180	158	3	22	Ø 18x8	
DN125	250	210	188	3	22	Ø 18x8	
DN150	285	240	212	3	24	Ø 23x8	
DN200	340	295	268	3	26	Ø 23x12	
DN250	405	355	320	3	29	Ø 27x12	
DN300	460	410	378	4	32	Ø 27x12	

Alternative flange dimensions are also possible e.g. according to US standards (ANSI), JIS etc.

* All the dimensions in the table are given in "mm".

** Subject to technical alterations and deviations resulting from the manufacturing process without giving any notification.

Reduction Factors for Pressure			
Temperature °C	Reduction Factor Kp	Temperature °C	Reduction Factor Kp
20	1,00	350	0,64
100	0,85	400	0,63
150	0,81	450	0,62
200	0,77	500	0,60
250	0,71	550	0,59
300	0,68	600	0,57

Pressure reduction factor

The reduction factor is used to define the design pressure [PS] where temperatures exceed 20 °C. It compensates for the decay in material mechanical properties at elevated temperatures. The calculated pressure is lower than the nominal pressure of the standard item.

Calculation: $PS \leq PN \times Kp$



X-PRESSED AXIAL EXPANSION JOINTS

X-Pressed Expansion Joints (One end with Fixed, other end with Floating Flange)

With fixed flange			
Type	Expansion Amount	Available Sizes (DN)	Pressure Class (PN)
DBKF-90	90 mm (-70/+20)	25-5000	16

With floating flanges			
Type	Expansion Amount	Available Sizes (DN)	Pressure Class (PN)
DBKF-120	120 mm (-100/+20)	25-5000	16

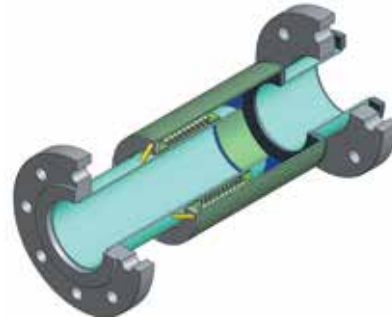
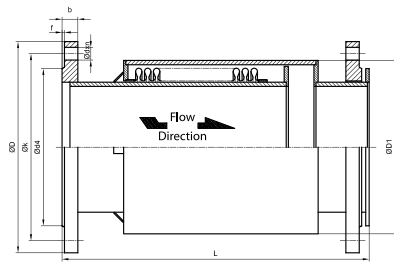

Bellows Information				DBKF-90			DBKF-120		
DN	Ødi	Ødo	Effective Bellows Area cm ²	L	Axial Spring Rate N/mm	Code	L	Axial Spring Rate N/mm	Code
DN25	38	48,2	14,58	520	41,1	702.060.203.002	600	34,2	702.060.204.002
DN32	42,4	55	18,62	520	24,8	702.060.203.004	660	17,7	702.060.204.004
DN40	48,3	61	23,44	530	30,4	702.060.203.006	680	20,3	702.060.204.006
DN50	60,3	76	36,46	510	55,7	702.060.203.008	680	32,1	702.060.204.008
DN65	76,1	95	57,45	500	43,9	702.060.203.010	740	23,6	702.060.204.010
DN80	88,9	111	78,42	500	89,4	702.060.203.012	650	55,9	702.060.204.012
DN100	114,3	140	137,09	510	126,1	702.060.203.014	690	78,8	702.060.204.014
DN125	139,7	164	181,01	520	160	702.060.203.016	700	100	702.060.204.016
DN150	168,3	200	266,20	540	98,2	702.060.203.018	700	70,1	702.060.204.018
DN200	219,1	250	431,86	560	347,1	702.060.203.020	770	198,3	702.060.204.020
DN250	273	323	697,11	570	295	702.060.203.022	830	177	702.060.204.022
DN300	323,9	380	972,37	600	248,4	702.060.203.024	810	149	702.060.204.024

Flange (DIN EN 1092/1) PN 16							
DN	ØD	Øk	Ød4	f	b	Ødxn	
DN25	115	85	68	2	16	Ø 14x4	
DN32	140	100	78	2	18	Ø 18x4	
DN40	150	110	88	3	18	Ø 18x4	
DN50	165	125	102	3	20	Ø 18x4	
DN65	185	145	122	3	20	Ø 18x4	
DN80	200	160	138	3	20	Ø 18x8	
DN100	220	180	158	3	22	Ø 18x8	
DN125	250	210	188	3	22	Ø 18x8	
DN150	285	240	212	3	24	Ø 23x8	
DN200	340	295	268	3	26	Ø 23x12	
DN250	405	355	320	3	29	Ø 27x12	
DN300	460	410	378	4	32	Ø 27x12	

Alternative flange dimensions are also possible e.g. according to US standards (ANSI), JIS etc.

* All the dimensions in the table are given in "mm".

** Subject to technical alterations and deviations resulting from the manufacturing process without giving any notification.

Reduction Factors for Pressure			
Temperature °C	Reduction Factor Kp	Temperature °C	Reduction Factor Kp
20	1,00	350	0,64
100	0,85	400	0,63
150	0,81	450	0,62
200	0,77	500	0,60
250	0,71	550	0,59
300	0,68	600	0,57

Pressure reduction factor

The reduction factor is used to define the design pressure [PS] where temperatures exceed 20 °C. It compensates for the decay in material mechanical properties at elevated temperatures. The calculated pressure is lower than the nominal pressure of the standard item.

Calculation: $PS \leq PN \times Kp$

X-PRESSED AXIAL EXPANSION JOINTS

X-Pressed Expansion Joints (One end with Fixed, other end with Floating Flange)

With fixed flange			
Type	Expansion Amount	Available Sizes (DN)	Pressure Class (PN)
DBKK-30	30 mm (-20/+10)	25-5000	16

With floating flanges			
Type	Expansion Amount	Available Sizes (DN)	Pressure Class (PN)
DBKK-60	60 mm (-40/+20)	25-5000	16

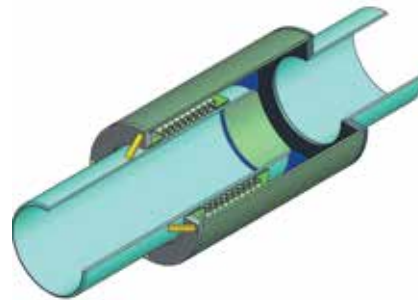
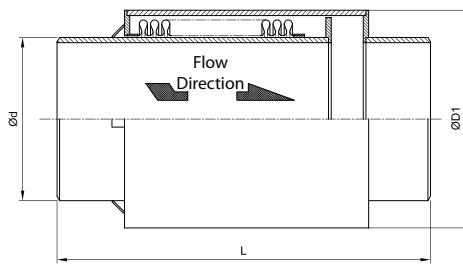

Bellows Information				DBKK-30			DBKK-60		
DN	Ødi	Ødo	Effective Bellows Area cm ²	L	Axial Spring Rate N/mm	Code	L	Axial Spring Rate N/mm	Code
DN25	38	48,2	14,58	340	82,1	702.060.101.002	470	41,1	702.060.102.002
DN32	42,4	55	18,62	340	49,7	702.060.101.004	470	24,8	702.060.102.004
DN40	48,3	61	23,44	360	60,8	702.060.101.006	480	30,4	702.060.102.006
DN50	60,3	76	36,46	350	104,5	702.060.101.008	460	55,7	702.060.102.008
DN65	76,1	95	57,45	350	87,8	702.060.101.010	450	43,9	702.060.102.010
DN80	88,9	111	78,42	350	178,9	702.060.101.012	450	89,4	702.060.102.012
DN100	114,3	140	137,09	360	252,2	702.060.101.014	460	126,1	702.060.102.014
DN125	139,7	164	181,01	360	320,0	702.060.101.016	470	160	702.060.102.016
DN150	168,3	200	266,20	380	196,4	702.060.101.018	490	98,2	702.060.102.018
DN200	219,1	250	431,86	400	694,2	702.060.101.020	510	347,1	702.060.102.020
DN250	273	323	697,11	420	590,0	702.060.101.022	520	295	702.060.102.022
DN300	323,9	380	972,37	440	496,8	702.060.101.024	550	248,4	702.060.102.024

* All the dimensions in the table are given in "mm".

** Subject to technical alterations and deviations resulting from the manufacturing process without giving any notification.

Reduction Factors for Pressure			
Temperature °C	Reduction Factor Kp	Temperature °C	Reduction Factor Kp
20	1,00	350	0,64
100	0,85	400	0,63
150	0,81	450	0,62
200	0,77	500	0,60
250	0,71	550	0,59
300	0,68	600	0,57

Pressure reduction factor

The reduction factor is used to define the design pressure [PS] where temperatures exceed 20 °C. It compensates for the decay in material mechanical properties at elevated temperatures. The calculated pressure is lower than the nominal pressure of the standard item.

Calculation: $PS \leq PN \times Kp$

X-PRESSED AXIAL EXPANSION JOINTS

X-Pressed Expansion Joints (One end with Fixed, other end with Floating Flange)

With fixed flange			
Type	Expansion Amount	Available Sizes (DN)	Pressure Class (PN)
DBKK-90	90 mm (-70/+20)	25-5000	16

With floating flanges			
Type	Expansion Amount	Available Sizes (DN)	Pressure Class (PN)
DBKK-120	120 mm (-100/+20)	25-5000	16

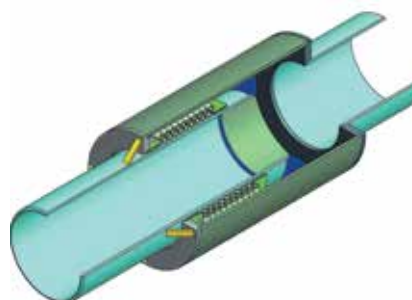
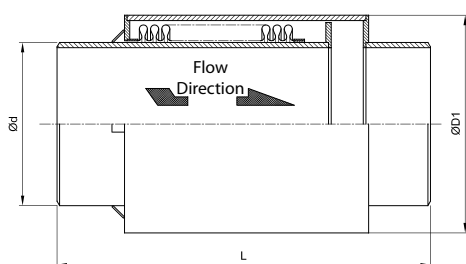

Bellows Information				DBKK-90			DBKK-120		
DN	Ødi	Ødo	Effective Bellows Area cm ²	L	Axial Spring Rate N/mm	Code	L	Axial Spring Rate N/mm	Code
DN25	38	48,2	14,58	500	41,1	702.060.103.002	580	34,2	702.060.104.002
DN32	42,4	55	18,62	500	24,8	702.060.103.004	640	17,7	702.060.104.004
DN40	48,3	61	23,44	510	30,4	702.060.103.006	660	20,3	702.060.104.006
DN50	60,3	76	36,46	490	55,7	702.060.103.008	660	32,1	702.060.104.008
DN65	76,1	95	57,45	480	43,9	702.060.103.010	720	23,6	702.060.104.010
DN80	88,9	111	78,42	480	89,4	702.060.103.012	630	55,9	702.060.104.012
DN100	114,3	140	137,09	490	126,1	702.060.103.014	670	78,8	702.060.104.014
DN125	139,7	164	181,01	500	160	702.060.103.016	680	100	702.060.104.016
DN150	168,3	200	266,20	520	98,2	702.060.103.018	680	70,1	702.060.104.018
DN200	219,1	250	431,86	540	347,1	702.060.103.020	750	198,3	702.060.104.020
DN250	273	323	697,11	550	295	702.060.103.022	810	177	702.060.104.022
DN300	323,9	380	972,37	580	248,4	702.060.103.024	790	149	702.060.104.024

* All the dimensions in the table are given in "mm".

** Subject to technical alterations and deviations resulting from the manufacturing process without giving any notification.

Reduction Factors for Pressure			
Temperature °C	Reduction Factor Kp	Temperature °C	Reduction Factor Kp
20	1,00	350	0,64
100	0,85	400	0,63
150	0,81	450	0,62
200	0,77	500	0,60
250	0,71	550	0,59
300	0,68	600	0,57

Pressure reduction factor

The reduction factor is used to define the design pressure [PS] where temperatures exceed 20 °C. It compensates for the decay in material mechanical properties at elevated temperatures. The calculated pressure is lower than the nominal pressure of the standard item.

Calculation: $PS \leq PN \times Kp$