



PKV-50

PNEUMATIC CONTROLLED ON/OFF VALVE

GENERAL FEATURES

Pneumatic valve works by moving single acting piston with air controlled actuator. Normally closed position. When the air moves to actuator, the piston moves upwards and the valve is opened. When the air is cut off, the piston is pushed through the spring and the valve is brought to the closed position. It is Y type valve as shown.

Applications:

Textile printing and painting
 Drug and medical equipment
 Food Facilities
 Organic and inorganic chemical industry
 Water / sewage discharge
 Paper factories
 Iron and steel factories

Fluids:

- Water
- Hot water
- Steam
- LPG, pressured gasses
- Gases such as oxygen, hydrogen and nitrogen
- Various chemical fluids

Installation:

Correct selection of installation should be done according to appropriate conditions. The arrow mark on the body must be in the direction of flow. It can be mounted in every direction. But in order to understand the open / closed position, it is beneficial that the drive head is in the place to be seen.

Advantages:

- Easy to use
- Easy installation
- Low energy consumption
- Long working life
- Reliability
- High Sealing
- Flow Control

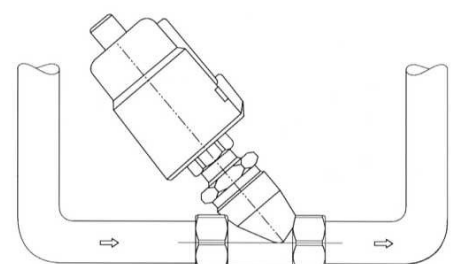

Flow Direction

Diameter	
DN (mm)	inch
15-50	1/2" - 2"

Technical Specifications	
Body	AISI 316 Stainless Steel
Connection	Threaded
Gasket	PTFE
Max. Working Pressure	16 bar
Max. Working Temperature	180°C
Air Supply Pressure Range	3-8 bar

PKV-50 PNEUMATIC CONTROLLED ON/OFF VALVE

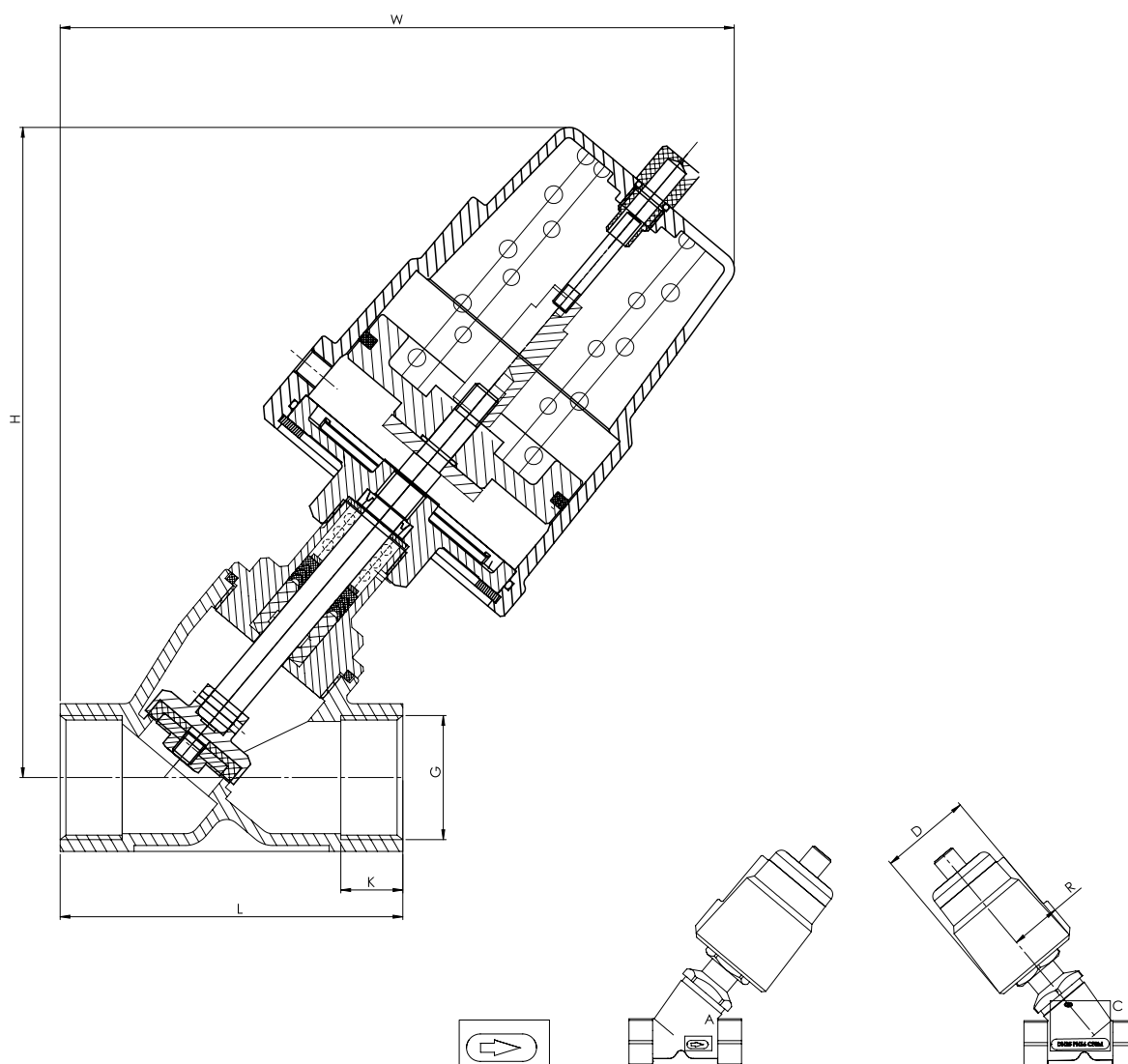

SPECIFICATIONS

Connexion	Inner Hole	Kv (m ³ /h)	Working Pressure	Control Pressure	Actuator (mm)
G 1/2	13	4,70	0-1,6	0,3 - 0,8	50
G 3/4	18	9,50	0-1,6	0,3 - 0,8	50
G1	24	18,10	0-1,6	0,3 - 0,8	63
G1 1/4	31	23,10	0-1,6	0,3 - 0,8	90
G1 1/2	35	32,90	0-1,6	0,3 - 0,8	90
G2	45	52,80	0-1,6	0,3 - 0,8	90

DIMENSIONS

DN(mm)	G(BSP)	L	H	W	K	D	SW	R	Weight
DN15	1/2"	68	125	135	15	60	27	33	1.02
DN20	3/4"	75	132	140	16	60	32	33	1.13
DN25	1"	90	162	172	17	75	40	41	2.13
DN32	1 1/4"	116	223	235	21	106	50	55	5
DN40	1 1/2"	116	223	235	21	106	56	55	5.12
DN50	2"	138	232	250	25	106	69	55	6

PKV-50 PNEUMATIC CONTROLLED ON/OFF VALVE

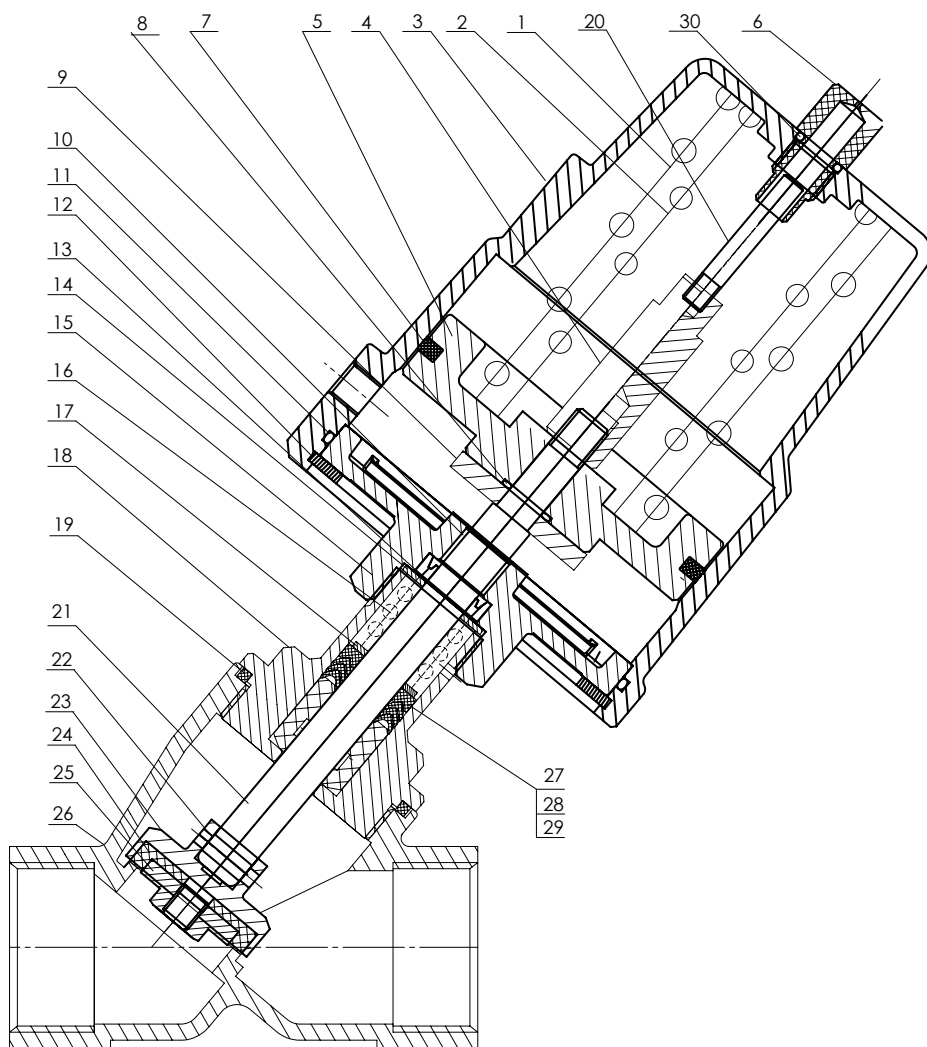

TECHNICAL SPECIFICATIONS		
No	Part	Material
1	SPRING 1	65Mn
2	SPRING 2	65Mn
3	ACTUATOR	CF8
4	NUT	ALLY12
5	PISTON	ALLY12
6	CAP	PC
7	PISTON RING	FPM
8	O RING	NBR
9	PISTON WASHER	304
10	BEARING	14X12X10
11	O-RING	NBR
12	CHECK RING	304
13	Y-RING	YPM
14	WASHER 1	304
15	COVER	CF8M
16	SPRING	304
17	WASHER 2	304
18	CONNECTION	CF8M
19	BODY SEAL	PTFE
20	INDICATOR	Nylon
21	STEM	304
22	ROUND PIN	304
23	VALVE CORE	CF8
24	SEAT/	PTFE
25	WASHER	CF8
26	BODY	CF8M
27	STEM SEAT 1	PTFE
28	STEM SEAT 2	PTFE
29	STEM SEAT 3	PTFE
30	O RING	NBR